

UV Monitor User's Manual

CHS4CM

■ Features

- Adopt MCU controller, high stability.
- Standard panel DIN48*48
- LED display
- Simple to handle
- Widely power supply 85~265VAC,
- Accumulated timing of UV lamp running-time
- UV irradiance low-alarm

■ Model Application

CHS4CM

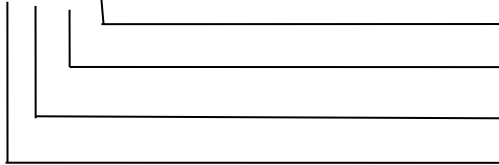

Monitor
Standard Model
48*48mm
Sunaay

■ Technical Parameter

Measuring range :	0~19999uW/cm ²
Resolution:	± (0.2%FS±1bit)
Input:	0~5VDC
Output:	Passive Relay Output(NO); (Contact capacity: 250VAC 3A/30VDC 3A)
Display:	LED display
Power supply:	85~265VAC 50/60Hz
Power consumption:	≤3W
Installation:	Embedded
Frame dimension:	48mm*48mm*107mm
Mounting hole dimension:	45mm*45mm
Weight:	320g
Operating Temperature:	0~+50℃
Humidity:	35~85% RH

■ Safety Note

- As UV Monitor is an electronic instrument, it should be installed and debugged by professional engineer
- Power-down before installation

■Wiring diagram

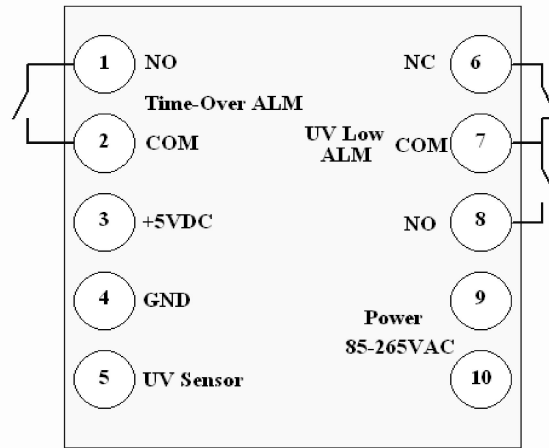

Terminal	Name
1,2	Time-over alarm output
3,4,5	UV sensor signal input
6,7,8	UV-value low alarm output
9,10	Power supply

Sensor line VS Terminal:

Blue: UV Sensor-5

Brown: 5VDC-3

Black: GND-4

■Setting

Parameter Code	Name	Range	Application
C-01	UV-low alarm value	0~100%	According to the actual requirement ,set the low alarming value.When the actual value lower than this value ,the delay will operate.
C-02	UV lamp life time	0~9999Hours	According to the life-length the manufacture supply,set this value.When the light running-time over the life-length,the time-over alarm relay will operate.

■Operating Discription

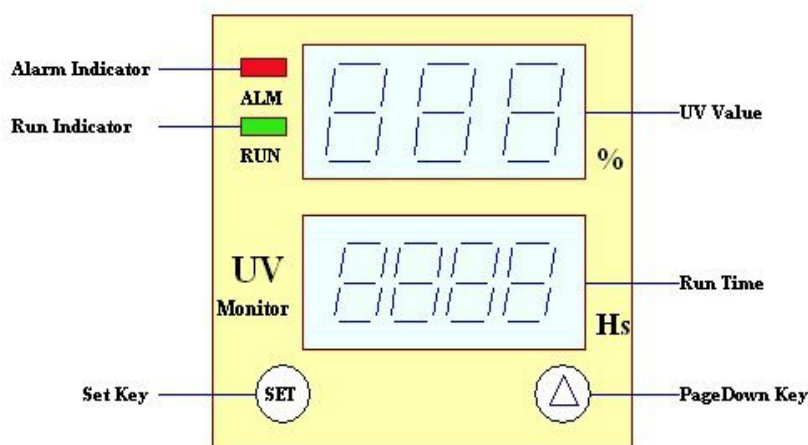

2. Instrument internal procedures

When the device is running for 130 hours, the instrument comes with the program will reset the internal 100%, This resets the UV intensity of 100% for the normal operation of the UV intensity average of 130 hours. This setting further improves the accuracy of UV monitoring.

3. Keys Function

Set Key:

1. 100% resetting and reset read-out to 0.
2. Parameter setting
3. Shifting the flash bit when setting the parameter

PageDown Key:

1. Change the display page of the parameter
2. Increase the flashing bit.

Pageup Key:

Press + together can enter or quit the parameter displaying page.

4. Operating steps and displaying pages:

Fig 2, Fig 3 is fault page of E-01 and E-02 problem.

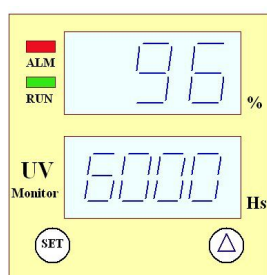

Fig 1

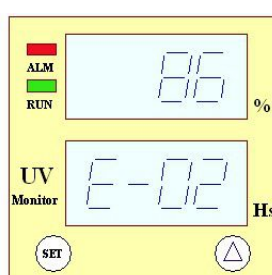

Fig 2

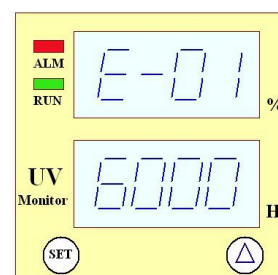

Fig 3

Steps of Resetting relative value to 100%

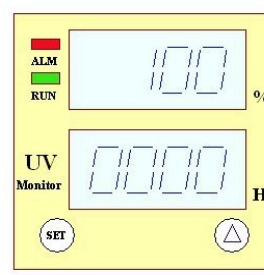
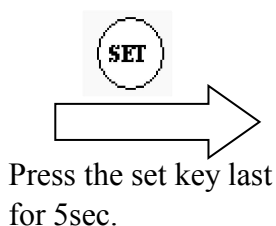
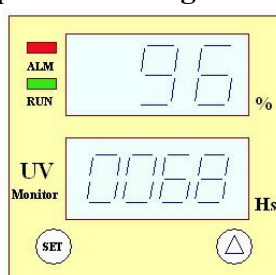

Fig 12

1. Press **SET** + **△** enter Fig 21.
2. Press **SET** enter Fig 22. and then Press the **△** key can increase the flashing number.
3. Press **SET** again, it will appear Fig 23, that flashing bit is shifted.
4. Press **SET** for 5 seconds until the flashing bit is fixed, the parameter will be memory.
5. Back from parameter setting: Press **SET** + **△** together

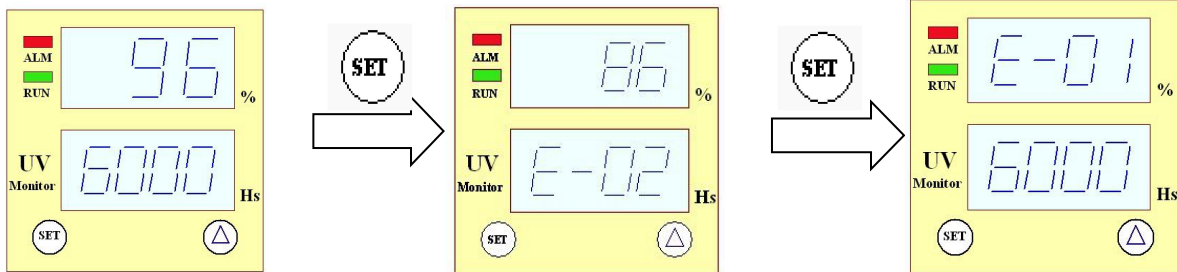

Fig 21

Fig 22

Fig 23

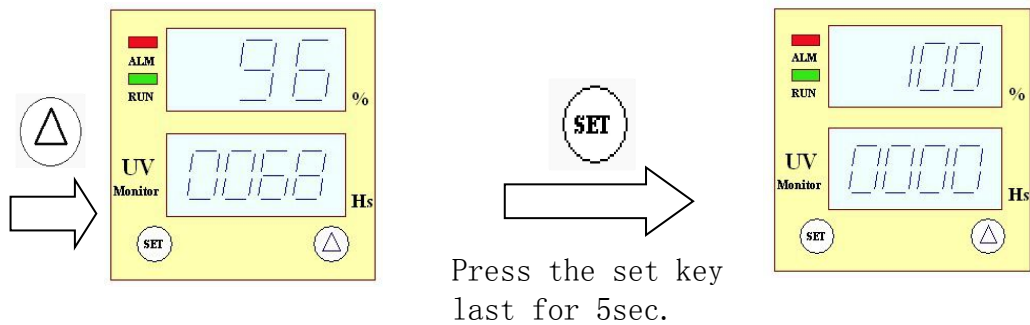

Fig 24

Fig 25

Setting steps for C-02 is same as above C-01 setting steps.

■Alarm codes instruction

Alarm code	Name	Application	Reason and solution
E-01	UV irradiance low alarm	When the UV relative value lower than the C-01 value, monitor will indicate the E-01, and the time-accumulator will stop working.	1. Quartz glass on the top of sensor is dirty. Cleaning it. 2. The irradiance of the lamp maybe weak, please replace the UV lamp.
E-02	Time-Over alarm	As the UV lamp running-time exceed to the life length value (can be set in the C-02), monitor will indicate E-02.	Replace the lamp.